

ROSSO E-QUAD

S
2021

ELECTRIC ATV



OWNERS MANUAL

**PRIOR TO FIRST USE, READ THIS MANUAL COMPLETELY AND ATTENTIVELY! IMPERATIVELY FOLLOW THE SAFETY INSTRUCTIONS!
NONOBSERVANCE CAN LEAD TO PERILOUS INJURIES! CAREFULLY KEEP THIS MANUAL!**

PLEASE INSPECT THIS EQUAD S UPON ARRIVAL AND REPORT ANY DAMAGES THAT MAY HAVE OCCURRED DURING SHIPPING

⚠ SAFETY WARNING ⚠

Riding an electric ATV can be dangerous. Like other electric products, electric ATVs can and are intended to move, and it is therefore possible to lose control, fall off and/or get into dangerous situations that no amount of care, instruction or expertise can eliminate. If such things occur the rider may be seriously injured or die, even when using safety equipment and other precautions.

⚠ RIDER ASSUMES ALL RISK, USE COMMON SENSE ⚠

This manual contains many warnings and cautions concerning the consequences of failing to maintain, inspect or properly use this eQuad. Because any incident can result in serious injury or even death, we do not repeat the warning of possible serious injury or death each time such a possibility is mentioned.

⚠ PROPER USE & ADULT SUPERVISION REQUIRED ⚠

This manual contains important safety information. It is the owner's responsibility to review this information and make sure that all riders understand all warnings, cautions, instructions and safety topics and ensure that young riders can safely and responsibly use this product.

Rosso Motors recommends that owners periodically review and reinforce the information in this manual with younger riders, and inspect and maintain this machine to ensure any rider's safety. An owner's decision to allow a child to ride this product should be based on the child's maturity, skill and ability to follow rules.

Keep this product away from small children and remember that this product is intended for use only by persons who are, at a minimum, completely comfortable and competent while operating the product.

SAFETY INFORMATION

ALWAYS follow safety information, product instructions and recommended maintenance and care, to ensure the best possible performance, lifespan and experience with a new eQuad!

ALWAYS wear proper protective safety equipment. (See details below)

ALWAYS check and obey any local laws or regulations that may affect the locations where the eQuad may be used.

ALWAYS ride defensively and hold the handlebars with both hands at all times.

ALWAYS ensure the rider is physically large enough to operate and control the quad. Rider weight does not necessarily mean they are large enough to physically reach controls.

ALWAYS watch out for potential obstacles that may collide with the quad or force the rider to swerve suddenly or lose control.

ALWAYS be careful to avoid pedestrians, skaters, skateboards, scooters, bikes, children or animals who may enter the eQuad's path, and respect the rights and property of others.

ALWAYS be careful and know rider limitations. The risk of injury increases as the degree of riding difficulty increases, The rider and adult supervisor assume all risks associated with aggressive riding activities.

ALWAYS regulate speed by applying both brakes when riding an eQuad downhill.

AVOID allowing more than one person to ride at a time. Not only can this be unsafe but it will reduce the eQuads performance and may damage the motor.

AVOID transporting cargo or towing other objects. Weight in excess of the recommended capacity (90lbs) will reduce the eQuads performance and may damage the motor.

AVOID riding near stairs, ledges, or excessively bumpy, uneven or steep slopes that may result in tipping or loss of control leading to accidents.

AVOID riding near bodies of water such as ponds, swimming pools or drainage ditches. Accidental submersion will most likely result in damage to the unit.

AVOID riding in wet or icy conditions as it may result in less traction and loss of control.

AVOID riding this eQuad on concrete, asphalt, etc. eQuad tires are designed for off-road use and treads will wear faster on hard abrasive surfaces.

AVOID riding at night or when visibility is limited and use vehicle lights as needed.

Continued next page...

NEVER immerse in or saturate the eQuad with water, as the electrical and drive components could be damaged by water or create other possible unsafe conditions. While shallow depths of water, such as shallow puddles or a few cm of mud or snow are most likely ok, avoid levels of water that may be near to or deeper than the unit's ground clearance. If excess moisture is splashed up within eQuads the body, use a towel to dry affected components to minimize the possibility of damage or corrosion.

NEVER ride the eQuad in any area where vehicle traffic is present. Intended usage is on private property and closed courses and not on public streets or sidewalks unless permitted by local regulations.

NEVER perform jumps or other aggressive riding as it can over-stress and damage the product, eQuads are manufactured for performance and durability but are not impervious to damage. The rider and adult supervisor assume all risks associated with such high-stress activity.

NEVER activate the throttle unless sitting properly on the eQuad and in a safe, open, outdoor environment suitable for riding.

NEVER use headphones or a cell phone when riding.

NEVER touch the brakes or electric motor on the eQuad when in use and/or immediately after riding as they can become very hot.

NEVER place fingers or any other body parts near the drive chain, steering system, wheels and all other moving components.

NEVER risk damaging surfaces such as carpets or flooring by riding an eQuad indoors.



DO NOT EXCEED WEIGHT LIMIT 90LBS (41KG)



PROPER RIDING GEAR

Always wear proper protective safety equipment whenever riding an eQuad. A helmet should always be worn to prevent injury and may be legally required by local law or regulations. A helmet with full protection for the chin and jaw in case of an accident is also recommended. This style of helmet can be purchased directly from our website in colours coordinated with most eQuads designs. Other safety gear such as wrist, elbow or knee protectors or gloves are also a great choice for extra protection.

Clothing for riding is also very important. Clothing should be properly fitted and weather-appropriate. Long-sleeved shirts and long pants are also helpful to minimize possible skin abrasions.

Always wear appropriate shoes that securely lace or velcro up and have rubber soles. Never ride barefoot, in sandals, flip flops or slides. Ensure that no articles of clothing in whole or in part are near to or capable of being caught in moving parts. (eg. untied laces, drawstrings, scarves, etc)

- The ROSSO eQuad S requires minimum assembly.
- Please follow the instructions below to get this eQuad S assembled properly.
- An assembly video can also be found at https://youtu.be/nx0eo_R491g.

1. Unboxing:

Carefully cut open the eQuad box and slide out the metal framed eQuad. Unbolt the lower frame bolts and remove the top portion of the cage. The eQuad can now be unbolted from the frame or left for now to keep the unit still, while the assembly process is finished. If left attached to the frame, unbolt before using. It is recommended to keep all packaging until assembly is complete to ensure no small parts are left behind. Check that the following smaller components are included.

Charger



Spare Fuse

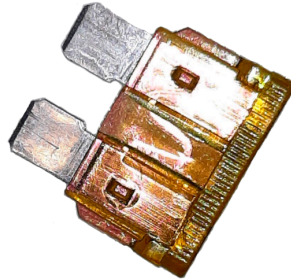

Handlebar Clamp

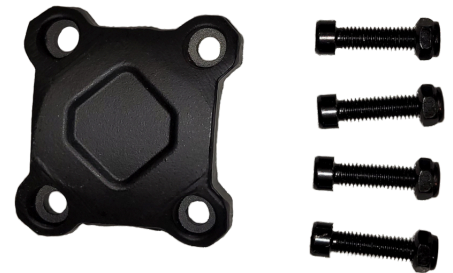

FNR Switch Knob



Fob w/ Ignition & Speed Keys



Tool Kit



ASSEMBLY continued...

2. Handlebar installation:

Place handlebars into position on the bracket on the top of the steering column, cover with the top handlebar bracket and loosely install 2 of the provided nuts & bolts in the set of holes closest to the rider. Slide the ignition switch plate between the front of the top and bottom bracket, aligning the holes. Install the remaining bolts into the front set of holes, adjust the handlebars to the desired position and tighten all hardware.



⚠ FAILURE TO PROPERLY ADJUST & TIGHTEN THESE BOLTS CAN CAUSE LOSS OF CONTROL & ACCIDENT ⚠

3. Fender installation:

Remove the bolts from the fender brackets located near each wheel. Align fender holes with the holes on the bracket and reinstall the bolts that were just removed, with the nuts on the inside of the fender.



4. Battery connection:

Locate the battery connection within the body and ensure the 2 connectors are together.



5. Final adjustments

Adjust the position of the brake levers, and secure them in place by tightening the single bolt.



(Please note: eQuad X handlebars shown, brake levers and adjustment procedure the same)

EQUADS COME ONLY PARTIALLY CHARGED AND MUST BE FULLY CHARGED BEFORE FIRST USE. SEE PG 07 FOR FULL DETAILS ON THE CHARGING AND BATTERY CARE.

COMPONENT DIAGRAM



- (a) Forward/reverse gear switch
- (b) Battery case
- (c) Controller/ charging port
- (d) 500W motor
- (e) 3-speed switch



- (f) Throttle/battery gauge & front brake
- (g) Rear brake & headlight/horn buttons
- (h) Headlights
- (i) Ignition switch

OPERATION

Basic Operation

With the eQuad powered on, gently twist the throttle until the desired speed is reached. Release the throttle and squeeze both brake levers to stop.

Charging

Step 1 - Ensure the eQuad is turned off (see instructions pg 08)

Step 2 - Plug the charger into a wall outlet. It should illuminate **green** indicating it is in ready/standby mode, if the indicator light does not come on double-check that the wall outlet has power.

Step 3 - Plug the charger into the charging port located within the body on the left side.

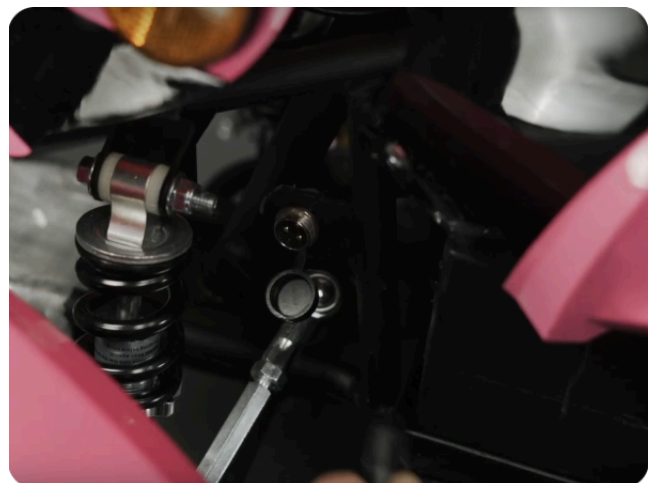

The charger's light should then change to **red** indicating that it is actively charging. The time for a full recharge is **6-8 hours**. Once fully charged the charger will switch back to the **green** light standby mode indicating that charging is complete and the charger can be removed. Do not leave charging overnight unattended. Chargers have built-in over-charge protection to prevent the batteries from being overcharged, however, unplugging the charger from the wall outlet when not in use is best for the charger itself. Batteries are only to be charged under adult supervision.

Run time is up to 120 minutes of ride time. Run time may vary depending on riding conditions, rider weight, climate, and/or proper maintenance. Constant stopping and starting may shorten ride time. For best results, charge the battery immediately after riding.

Fully charge the battery before storing for it an extended period and then every **3-5 weeks**. Failure to recharge the battery periodically may result in reducing the battery's overall lifespan or result in a battery that will not accept a charge. Make sure the eQuad is turned OFF when the unit is not in use for the least amount of battery discharge.

To ensure long battery life, never store the product in freezing or below-freezing temperatures! Freezing will permanently damage the battery. Always disconnect the charger before wiping down and/or cleaning the eQuad.

Chargers may become warm or emit sound during regular use, this is a normal response and is no cause for concern. Oppositely if it does not do either that does not indicate it is not working properly. If the charger becomes very hot, please unplug it and contact Rosso Motors technical support. The charger supplied with the eQuad should be regularly examined for damage to the cord, plugs, enclosure and other parts. In the event of such damage, the eQuad must not be charged until it has been repaired or replaced.

⚠ CHARGE THIS EQUAD WITH THE SUPPLIED CHARGER ONLY. EQUADS MUST BE REGULARLY CHARGED TO MAINTAIN THE BATTERIES AS DESCRIBED ABOVE ⚠

Ignition Switch / Alarm & Key Fob





The eQuad S can be turned on/off using **2** different methods:

MANUALLY by placing the **key** into the ignition switch (located on the right side of the eQuad) and turning it to the on position. Once turned on manually, the eQuad can **ONLY** be turned off by manually turning the key back to the off position.

REMOTELY via the included remote **fob**. Once the eQuad has been turned on remotely it can **ONLY** be turned off with the fob.

Continued next page...

Remote Buttons

-  POWER 2x press to turn the unit NO
-  UNLOCK Press to turn the unit OFF and to turn the alarm off
-  LOCK Press to turn the unit's alarm on.
-  SIREN Press to activate the siren for locating a unit

Each fob requires a CR2032 battery. (pre-installed) To replace the battery remove the key ring, then carefully pry off the silver side pieces. Once removed the black fob body can be separated revealing the interior and battery slot. Once a new battery is installed, reassemble the fob in the reverse order.

Battery Level Indicator

The battery level indicator is located on the throttle handle on the right handlebar. The lights indicate the current battery level from full to empty and are also an easy way to tell if an eQuad is turned on. When turned off, if the lights do not turn off, it may indicate that the eQuad was started with the other method of power up. (Manual keys vs Remote fob) Please see the previous page for details.

3 Speed Switch

Using the provided speed switch keys, the speed setting can be changed by turning the key to the desired speed. Once the speed is set and key removed the eQuad is locked into that speed setting. Do not leave the key in the 3-speed switch while operating the eQuad. Quad S speeds are: **(L)**ow 4-8 km/h, **(M)**edium 11-13 km/h, **(H)**igh 16-20 km/h

FNR Gear Shifter

To change between **(F)**orward, **(N)**eutral and **(R)**everse, while stationary, turn the gear shift knob, to the desired position. **Always bring the vehicle to a complete stop before changing gear, failing to do so will result in damage to the switch.**

Parking Brake

Locate the parking brake knob on the right brake lever. To engage the parking brake, squeeze the front brake lever and press down the parking brake knob. To disengage the parking brake squeeze the brake lever until the knob pops up.

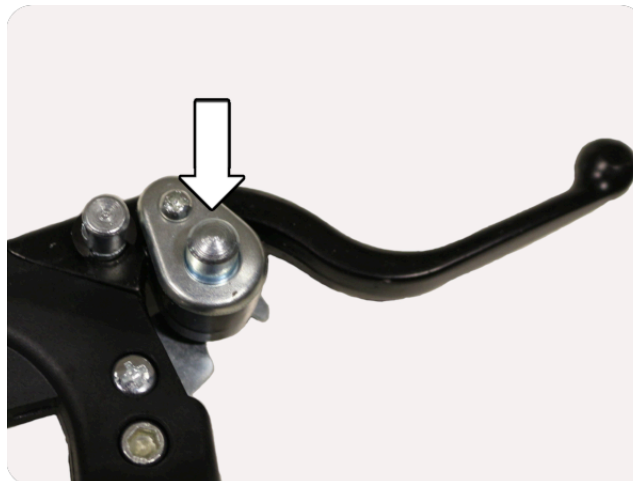

Headlight/Horn switch

Located on the left handlebar the **red** headlight switch can be used to turn the headlights on and off.

PRE-RIDE CHECKLIST

Ensure to check the following before each ride to ensure maximum safety:

- Brakes** - Check the brakes for proper function. When squeezing each brake lever, the brake caliper should prevent movement.
- Tires** - Inspect tires for excess wear and replace as needed. Riding on abrasive surfaces such as concrete or asphalt will increase tire wear. Regularly check the tire pressure and inflate as needed. *Recommended tire pressure: 7 PSI. (Maximum: 20 PSI)*
- Frame & Handlebars** - Check for loose, cracked or broken connections, and proper alignment. Although broken frames are rare, aggressive riding can lead to a strong enough collision to bend or break the frame.
- Hardware** - Check and secure all fasteners (nuts, bolts) before every ride. If the unit is damaged, do not ride it.
- Rider** - Ensure the rider can operate the eQuad and is wearing proper clothing and safety equipment as described on pg 03.
- Location** - Ensure the area is open and free of hazards. Follow any laws or regulations.

MAINTENANCE

Cleaning

Wipe surfaces off with a damp cloth and neutral detergent. Do not clean with a pressurized source of water.

⚠ MAKE SURE THE POWER IS PROPERLY TURNED OFF BEFORE PERFORMING ANY CLEANING, MAINTENANCE OR ADJUSTMENTS ⚠

Brake adjustments

Failure to inspect and properly adjust brakes increases the risk of having an accident. Riding with worn brake pads can reduce braking performance and cause an accident. Check and adjust brakes if needed before each ride.

To adjust cable play on the left (rear) brake lever – tighten/loosen adjuster

To adjust cable play on the right (front) brake lever - tighten/loosen adjuster

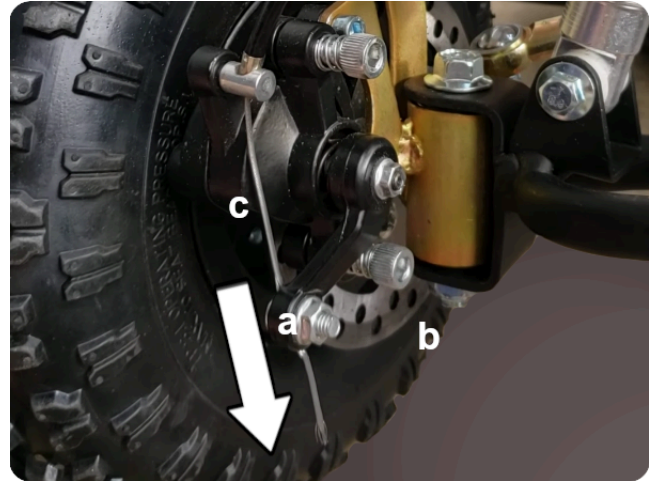

To adjust the calipers, loosen (do not remove completely) the anchor nut (a) and pull the brake cable (c) until the brake pads are almost touching the rotor (b). Tighten the anchor nut (a).

Wheel Alignment

In the event that the front wheels aren't straight the wheel alignment will need to be adjusted. Start by straightening the handlebars. Locate the tie rod on the wheel to be straightened, the tie rod consists of a center rod and 2 ends. Each end is held to the center rod with a securing nut (a). Loosen the securing nuts (a) on both the tie rod ends, once both are loosened turn the center rod (b), this will turn the wheel in or out depending on the direction it's turned. Once the wheel is straight and in the correct position re-tighten the 2 securing nuts (a). This procedure is the same for both sides of the eQuad.

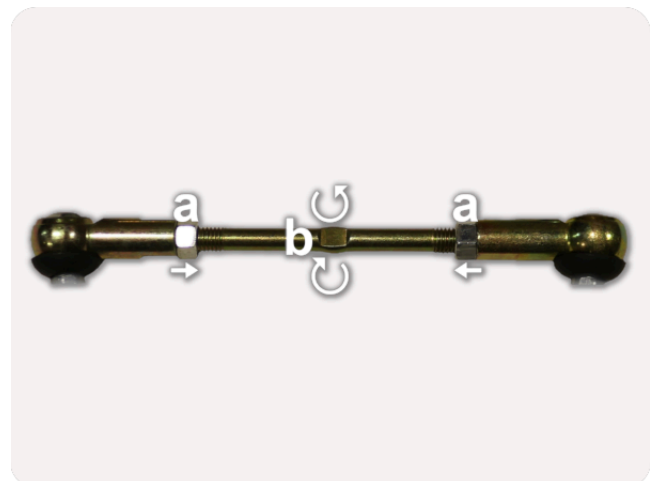
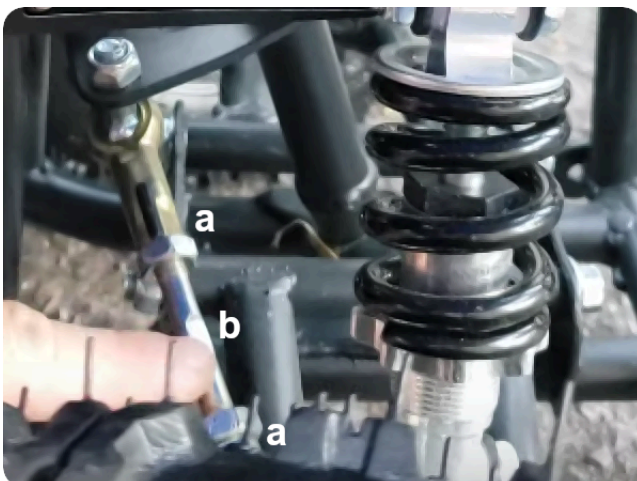

Chain

The eQuad is chain-driven and should be periodically lubricated with lithium spray. The chain may make some clicking noises, this is **normal**. Always inspect, maintain or adjust the chain, if necessary, before each ride. Riding with a chain in poor condition or one improperly adjusted, can lead to serious injury. If the chain is loose, wobbly or falling off, which may happen over time with stretching with use, it will need to be tightened. Before adjusting the chain, make sure the motor is cool. **Do not touch the motor immediately after use. The motor will be, or can be, very hot, always allow it to cool.**

To tighten the chain, first loosen, but don't remove, the four nuts(a) securing the motor to the frame. (2 in front and 2 in behind) Once loosened the tensioners located in front of the motor can be adjusted to shift the motor forward tightening the chain. One at a time, turning clockwise, tighten the nut(b) on each chain tensioner, ensuring to tighten each side an equal amount. Adjust both tensioners equally until the chain is properly snug, do not over-tighten the chain. Once adjustments are complete retighten the 4 nuts(a) previously loosened. Now is also a great time to lubricate the chain.

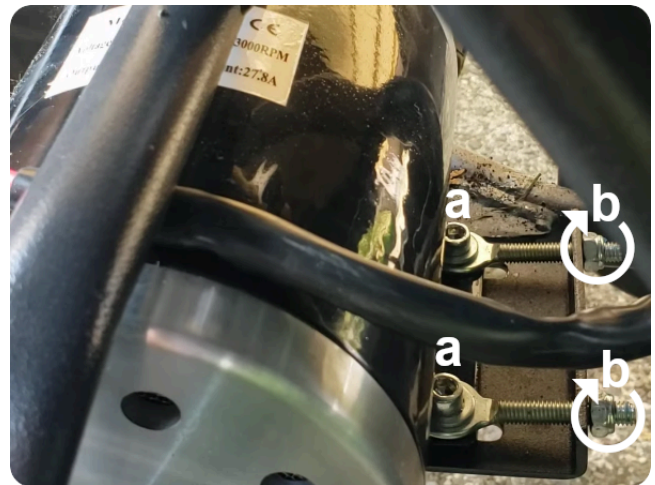
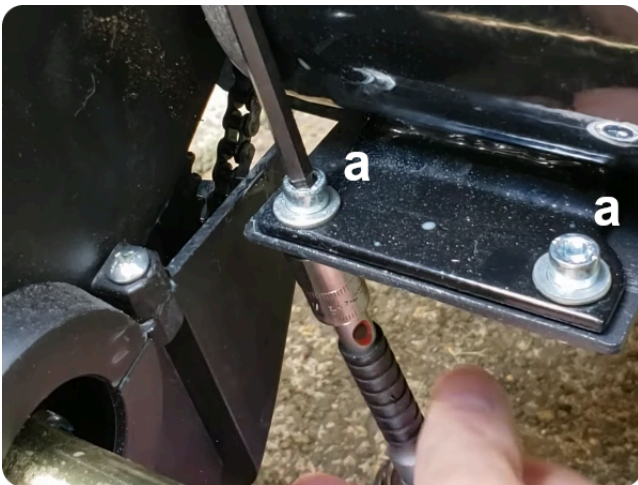

Wiring Diagram

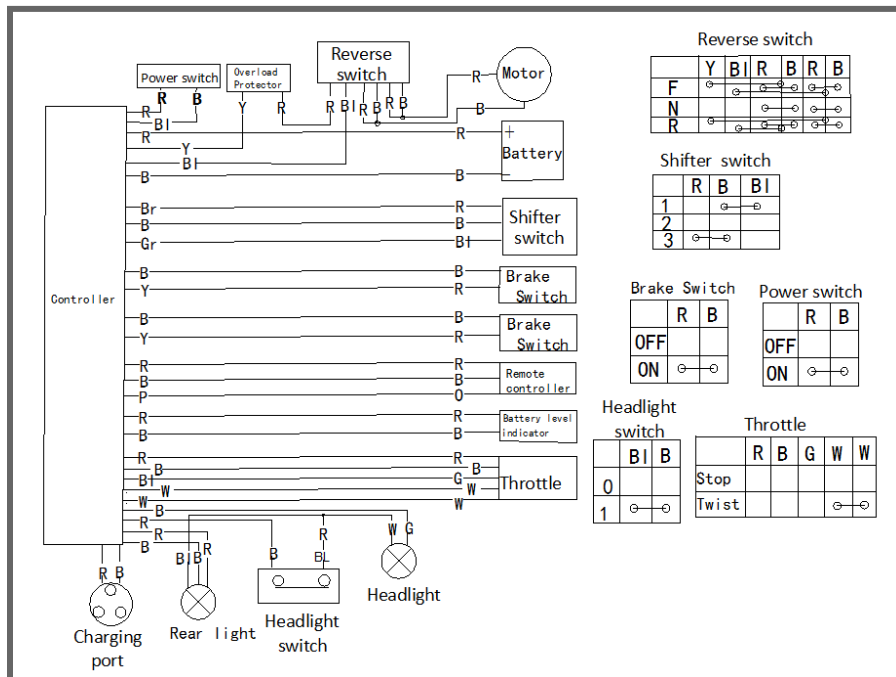

TROUBLESHOOTING

Problem	Possible Cause	Solution
Power does not turn on	Fuse not installed/burnt out	Replace fuse
	eQuad is turned off	Turn main switch on / activate with remote fob
	Battery not connected	Connect battery
	Battery not charged	Charge battery
	Loose connection	Check connections on the battery, controller & main switch
Power ON but doesn't move	Throttle failure	Check throttle connections or replace throttle
	Brakes are too tight	Adjust brakes
	Motor connections loose	Check and tighten connections
	Brake lever not released	Release brake lever
	Gear shifter failure	Check connections to gear shifter or replace if necessary
Low travel distance	Battery low/ not charged	Charge battery
	Low tire pressure	Inflate tires
	Chain is loose	Adjust chain
	Over weight capacity	90lb recommended weight capacity
	Brakes are too tight	Adjust brakes
eQuad not charging	No power at the outlet	Check power to the outlet
	Charger damaged (no lights)	Replace charger
	Battery damaged	Refer to page 08 for battery care

The tips above are a basic troubleshooting guide. Please contact our technical support for help with any issues, technical questions or concerns.

ROSSO MOTORS warrants this product to be free of manufacturing defects for a period of 6 months from the date of purchase. This limited warranty does not cover normal wear and tear components, (tires, tubes, brake cables, etc) or any damage, failure or loss caused by improper assembly, maintenance, care, storage or use of the **eQuad S**.

This Limited Warranty is voided if the product is:

- Used in a manner other than for recreation
- Modified in any way
- Rented

ROSSO MOTORS is not liable for incidental or consequential loss or damage due directly or indirectly to the use of this product.

For more information on the warranty please see our FAQ section online:

www.rossomotors.ca/pages/faq

For any request regarding warranty, spare parts or replacement devices do not hesitate to contact us by phone or e-mail. Office hours are Monday to Friday 9am to 4pm PST. Have an order number or order information ready before contacting us.

E-Mail:

hello@rossomotors.com

Telephone:

[1-888-897-5909](tel:1-888-897-5909)



11400 Twigg Place Unit 1
Richmond, BC, V6V3C1
CANADA

hello@rossomotors.com
www.rossomotors.ca
1-888-897-5909

© Rosso Motors, 2024. All Rights Reserved